



Contents

	Machine Specification Sheet	Page 1a/1b
Section 1	Technical Specification	Page 3
Section 2	Description of Operation	Page 5
Section 3	Diagram of Parts	Page 6
Section 4	Control Panel	Page 7
Section 5	Operating Overview	Page 8
Section 6	Setting up the Machine	
6.1	Loading the Paper Hopper	Page 9
6.2	Setting the Fold Plates	Page 9
6.2.1	Fold Plate 1	Page 9
6.2.2	Fold Plate 2	Page 10
6.2.3	Using the No-Fold Guide	Page 10
6.2.4	Fold Options	Page 11
6.3	Double Document Calibration	Page 13
Section 7	Handfeed Option	Page 13
Section 8	Operator Maintenance	
8.1	Cleaning the Fold Rollers	Page 14
8.2	Cleaning the Sensors	Page 15
8.3	Clearing Paper Jams	Page 16
Section 9	Supervisor Mode	Page 17
Section 10	Operator's Troubleshooting Guide	Page 18
Section 11	Fault Messages	Page 19

DONNEES TECHNIQUES DE LA MACHINE

1. **ATTENTION:** Afin de garantir un fonctionnement en toute sécurité, cette machine doit être installée et entretenue par un technicien agréé.
 2. **ATTENTION:** Si le couvercle ou le mécanisme de blocage de sécurité est endommagé, ne pas utiliser la machine tant que les réparations n'ont pas été effectuées.
 3. **ATTENTION:** **Cette machine doit être raccordée à la terre.** Les fils de couleur du câble d'alimentation sont:

110-120V	220-240V	Connecté:
Vert	Vert/Jaune	à la terre (masse).
Blanc	Bleu	au neutre.
Noir	Brun	à la tension.
 4. **ATTENTION:** Cette machine ne doit pas être utilisée si le câble d'alimentation est endommagé. Il y a lieu de le remplacer par un câble similaire:

UK	N° de pièce 162-210
EURO	N° de pièce 162-311
US	N° de pièce 162-321
 5. **ATTENTION:** Pour ne pas compromettre la protection contre les risques d'incendie, remplacer par un fusible de même type et de mêmes caractéristiques nominales:

110-120V	T5A 250V	N° de pièce 135-105
220-240V	T5A 250V	N° de pièce 135-105
 6. **Spécifications:**

Nom du modèle:	<u>AS300/500 Pressure Sealer</u>	
Numéro du modèle:	<u>AS03/AS05</u>	
Tension d'entrée:	<u>110-120V à 60Hz</u>	<u>220-240V à 50 Hz</u>
Courant d'entrée:	<u>3A</u>	<u>1,5A</u>
Puissance d'entrée:	<u>360W</u>	<u>360W</u>
Niveau de bruit:	<u>75 dBA</u>	<u>75 dBA</u>
(mesuré en insérant un seule feuille dans une enveloppe à une distance de 1 mètre du capot le plus proche et à 1,6 mètre du sol).		
Poids:	<u>98lbs (44.5kg) déballée</u>	
- Le levage ou la manipulation de la machine ne peut être effectué que par des personnes qualifiées utilisant l'outillage approprié.
7. Cette machine est conçue tout spécialement pour fermer avec la pression les documents.



IMPORTANT! READ THIS FIRST

Safety Precautions

Observe the following safety precautions at all times when running the AS300 or AS500 Pressure Sealer.

- Be sure you know how to switch the machine off in the event of an emergency.
- Do not try to use this machine until you have read these Operating Instructions and fully understand its operation.
- Keep loose clothing, long hair and jewellery clear of all moving parts.
- Do not touch any moving parts. When opening the covers, ensure that all moving parts have come to a halt before touching them.
- Do not attempt to dismantle any part of the machine, or remove any fixed covers - this could result in risk of electric shock or fire. If service attention is required, call a PFE Service Engineer.
- If damage to any cover has occurred, it must be replaced by a PFE Service Engineer.
- If any access cover safety switch fails allowing the machine to continue operating when the cover is opened, call a PFE Service Engineer immediately.
- Do not cover any vents or openings, or overheating may result.
- Avoid placing any objects on top of the machine - they could topple off and create a safety hazard.
- Do not attempt to operate the machine with product outside the limits shown in the specifications.
- Ensure you have free access all round the machine for loading paper hoppers etc. Do not place surrounding furniture or other objects where your path may be obstructed.
- **The machine must use a stand capable of supporting at least 57kg (125lbs).**

PUT SAFETY FIRST!



AS300/500 PRESSURE SEALER

SECTION 1 TECHNICAL SPECIFICATION

Form Size:

Standard Lengths: 11", 11.69", 12" & 14" (279.4, 297, 304.8, 355.6mm)

Standard Widths: 8.27" & 8.5" (210 & 215.9mm)

Fold Types:

Standard V-Fold: 8.5 x 11", 210 x 297mm & 210 x 304.8mm

Standard C-Fold: 8.5 x 11", 8.5 x 14", 210 x 297mm & 210 x 304.8mm & 210 x 355.6mm*

Standard Z-Fold: 8.5 x 11", 8.5 x 14", 210 x 297mm & 210 x 304.8mm & 210 x 355.6mm

Eccentric Z-Fold: 8.5 x 11" Form: Top Panel 4.25", Mid Panel 4.25", Bottom Panel 2.5"

8.5 x 14" Form: Top Panel 5.25", Mid Panel 5.25", Bottom Panel 3.5"

or 8.5 x 14" Form: Top Panel 5.5", Mid Panel 5.5", Bottom Panel 3"

Return Envelope: 8.5 x 14" C-Fold*: Panel sizes of 3.25", 5.38", 5.38"

8.5 x 14" Z-Fold: Equal panel sizes of 4.66"

* C-Fold uses optional long fold plate 1.

Paper Weight:

24 or 28 lbs bond (North America)

96, 100 or 115 gsm (Europe)

Hopper Capacity:

AS300: Up to 100 sheets of 120gsm (28 lbs bond)

AS500: Up to 150 sheets of 120gsm (28 lbs bond)

Output Tray Capacity:

Up to 100 mailers, 3-ply sealed of 28 lbs bond (120gsm)

Operating Speed:

AS300: 3,000 fph (8.5 x 11")

AS500: 5,000 fph (8.5 x 11")



Volume:

Up to: 45,000 documents/month

Physical Dimensions:

Length: 15.5" (390mm), tray retracted
21" (535mm), tray extended

Width: 18.5" (470mm)

Height: 18.5" (465mm) to top of hopper tray
21" (530mm) to top of optional long fold plate 1

Footprint: 13.5" (345mm) long x 18.5" (470mm) wide

Electrical:

	<u>US</u>	<u>Europe</u>
Voltage:	115V @ 60Hz	230V @ 50Hz
Current:	3A	1.5A



SECTION 2 DESCRIPTION OF OPERATION

The function of the AS300 or AS500 Pressure Sealer is to feed unfolded forms from a stack, fold them either once or twice, seal the cohesive edges and place them into a receiving tray. Forms can be 'C', 'Z' or 'V' in standard fold, or Eccentric 'Z', and also 'C' or 'Z' fold with pressure seal return envelope (all 'C' folds require optional long fold plate 1). There is also a handfeed facility to seal pre-folded forms. This feature may also be used to seal a diverted form. The difference between the two machines is the speed (3000 forms per hour for AS300, 5000 forms per hour for AS500) and the hopper capacity (100 forms for AS300 and 150 forms for AS500). All other features are identical.

Prior to use for the first time, or after a change of form type the machine can be calibrated to detect double documents. Subsequently, if more than one form is fed (eg. two together), these will be diverted out of the top of the machine before reaching the sealing rollers. The form used for calibration will also be diverted in this way (which allows checking of folds and ensures that only a single document was fed).

A jog function is provided, which operates the machine in short 'spurts' in order to help clear forms through the paper path. A fault number (in the form 'FLt nn') will appear on the control panel, and this will be accompanied by a message describing the fault, the description of which will be shown scrolling on the display. These faults are also shown in Section 10 of this document. The display also indicates the forms count when the machine is running, and the counter may be reset to zero at any time, eg. when starting a new job. Note that if the button is pressed by mistake, the count can be recalled by pressing the button again.



SECTION 3 DIAGRAM OF PARTS

Shown below are the main sections of the AS300 or AS500 Pressure Sealer.

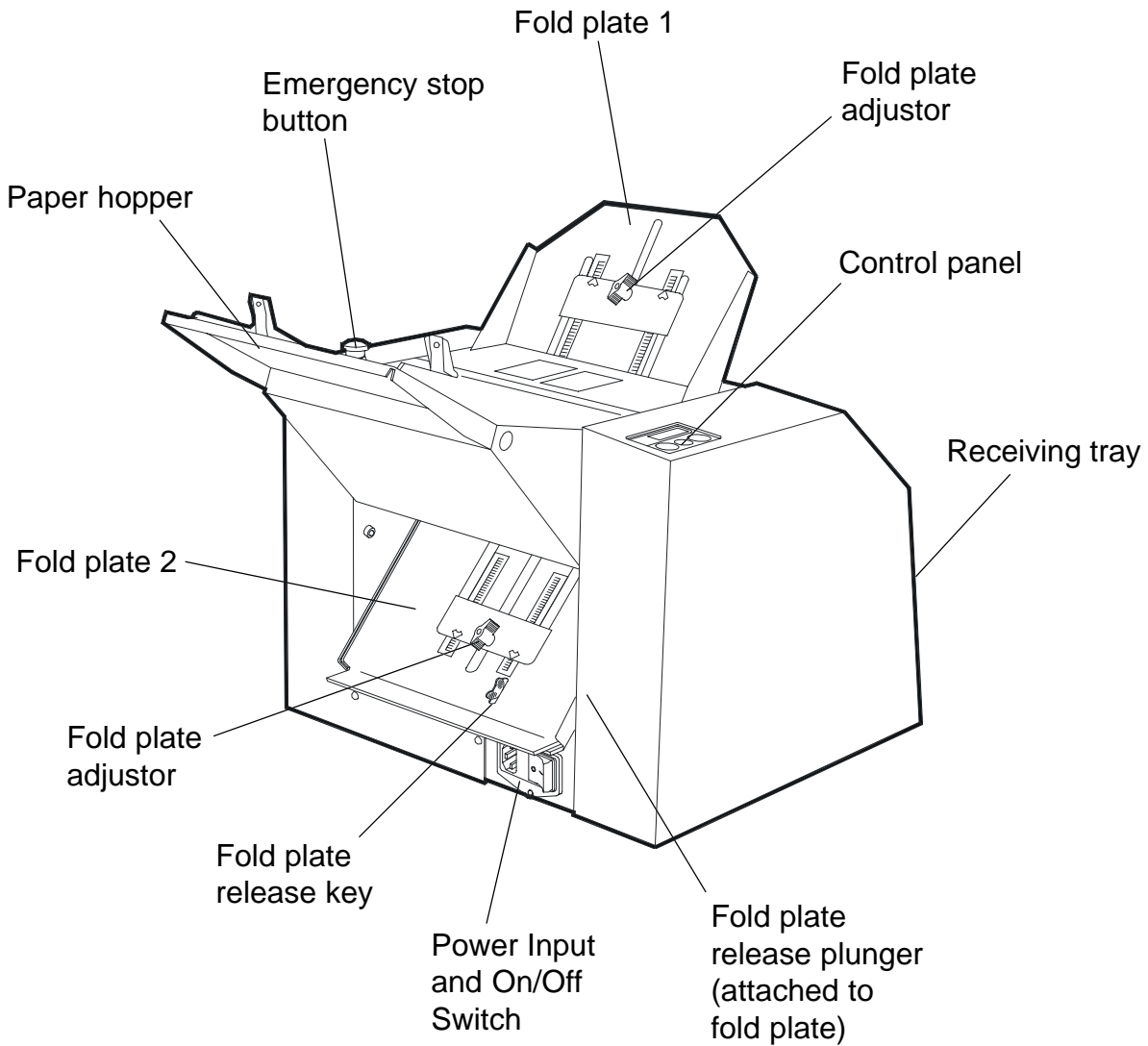



SECTION 4 CONTROL PANEL

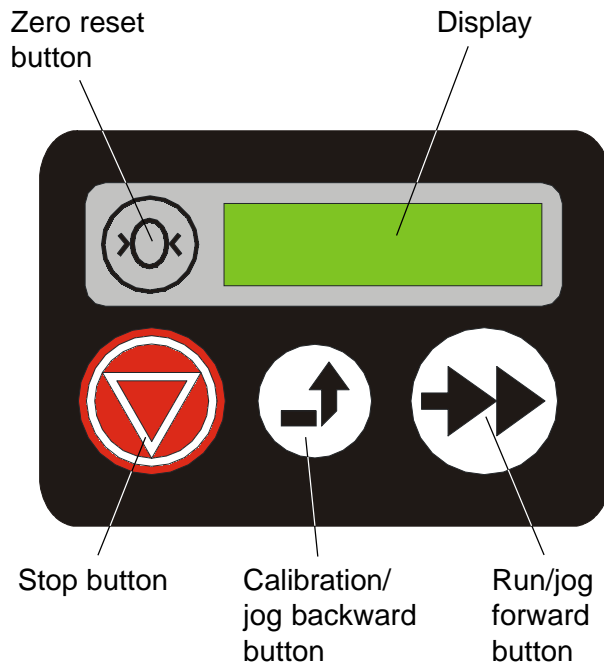

Button/Item Description

Button/Item

Function

Zero reset button:

Sets the forms count on the display to zero. (Press again to restore count)

Display:

Indicates forms count, error messages, assistance messages and error codes (see Section 10 for error code look-up table).

Calibration button:

Calibrates a form for doubles detection and ejects it in front of no.1 fold plate at the top of the machine. Also used as a jog backward button to clear paper jams (see Section 8.3).

Run Button:

Starts the machine operating. Also used as a handfeed button (see Section 7) and as a jog forward button to clear paper jams (see Section 8.3).

Stop button:

Stops the machine operating. Press once to stop at the end of the current cycle.



SECTION 5 OPERATING OVERVIEW

Shown below is an operating summary of the machine. Further details may be found in the section indicated.

ACTION	PAGE
5.1 Plug in the machine and switch on.	6
5.2 Load paper into the paper hopper.	9
5.3 Extend the receiving tray. This may be set to accommodate the size of the folded form.	n/a
5.4 Set the fold plates to the required positions.	9
5.5 Calibrate for double document (only required once, or if the paper type changes). Make sure only one form was fed.	13
5.6 Press the Run button to begin operating. Press the Stop button to feed through the current form and then stop.	7
5.7 When finished, switch off the machine.	6

NOTE

TO STOP THE MACHINE IN AN EMERGENCY, PRESS THE RED, DOMED BUTTON ON THE TOP OF THE SIDE COVER OPPOSITE THE CONTROL PANEL



AS300/500 PRESSURE SEALER

SECTION 6 SET UP

6.1 LOADING THE PAPER HOPPER

2. Adjust the width of the side guides to give 0-1mm (approx, 1/32") clearance on each side.

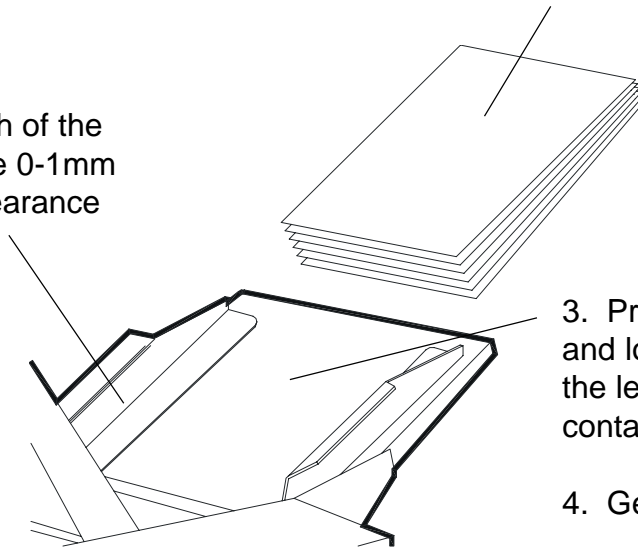

1. Fan a stack of forms (max. 100) and align the edges.

3. Press down on the tray and load the forms. Ensure the leading edges are contacting the chassis.

4. Gently release the tray.

6.2 SETTING THE FOLD PLATES

There are 2 fold plates, allowing 'C' (or letter) fold or 'Z' (accordian) fold, either equal or eccentric. Fold plate 1 is located on top of the machine and fold plate 2 is located on the rear face below the paper hopper. The machine is fitted as standard with a short fold plate 1, with an optional long fold plate required for 'C' folds. If a single ('V') fold only is required, either equal or eccentric, a no-fold guide is actuated for fold plate 1 (see [section 6.2.3](#)). See also [section 6.2.4](#) for details on fold options.

6.2.1 Fold Plate 1

Loosen the knob and adjust the stop so that the top edge of the backstop plate aligns with the scale measurement of the 1st. fold length (see [section 6.2.4](#)). Retighten the knob.

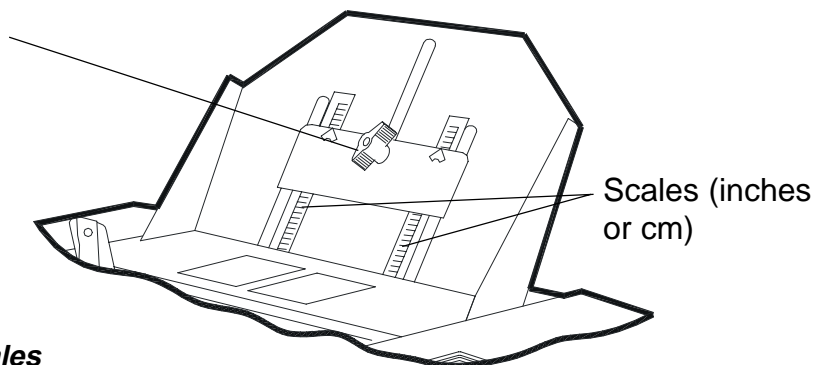

Note that one of the scales shows commonly used sizes.



6.2.2 Fold Plate 2

Loosen the knob and adjust the stop so that the bottom edge of the backstop plate aligns with the scale measurement of the 2nd. fold length (see section 6.2.4). Retighten the knob and close the cover.



Note that one of the scales shows commonly used sizes.

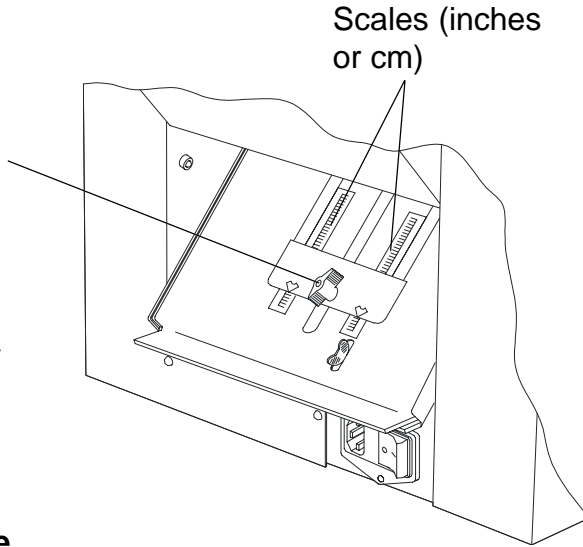

6.2.3 Using the No-Fold Guide

If a single fold is being used, the no-fold guide must be brought into position. The guide is a pivoting member located beneath fold plate 1. Also see section 6.2.4 for fold options.

1. Hinge fold plate 1 back so that it is fully open.

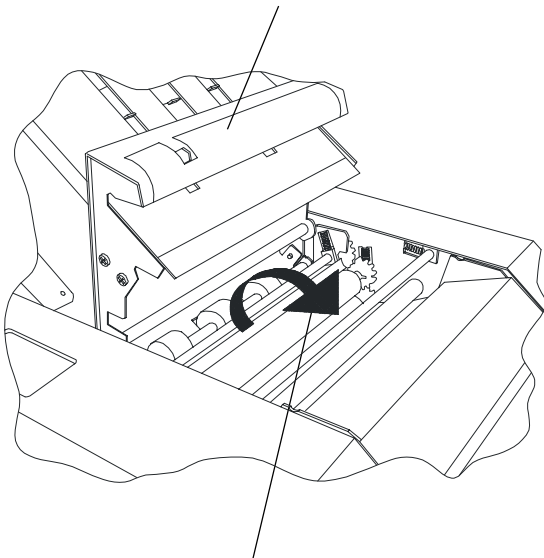

2. Swing the no-fold guide forwards so that it is pointing upwards

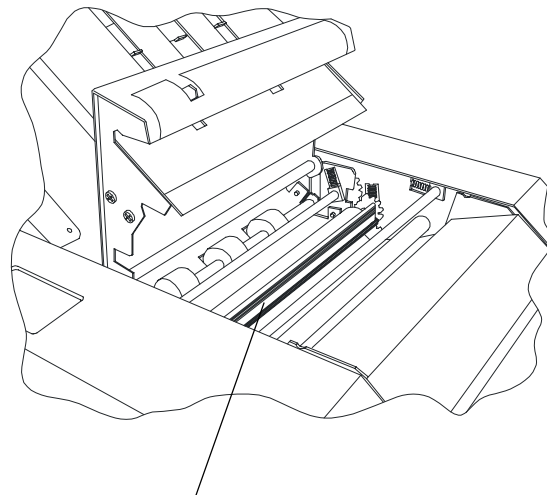

Guide in no-fold position.

3. Close fold plate 1. The machine is now set up for single fold.



When single fold is no longer required, remember to swing the guide back to its stored position.



6.2.4 Fold Options

Indicated below are the three types of folds that may be used. Use the arrow as a guide to which way the paper should be stacked on the tray; normally the address will be on the same side and at the same end as the arrow. Use the ruler on fold plate 1 for measuring the folds.

Letter (or Wallet/'C') Fold

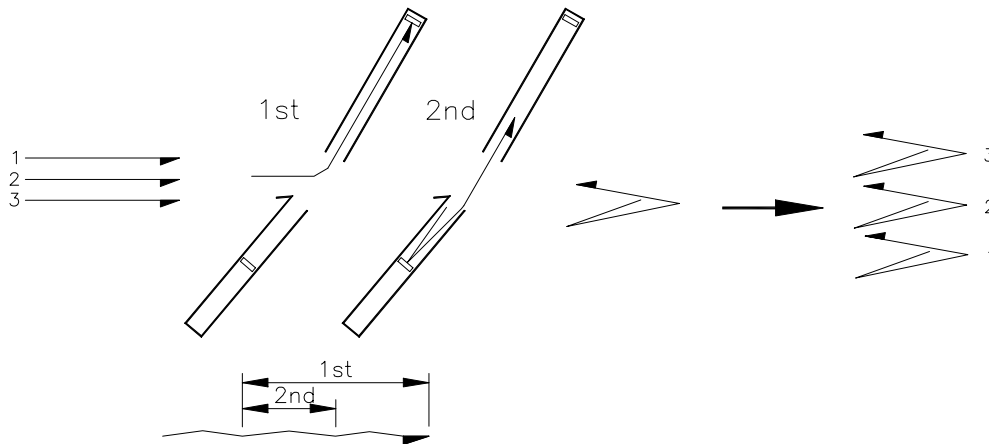

Accordian (or 'Z') Fold

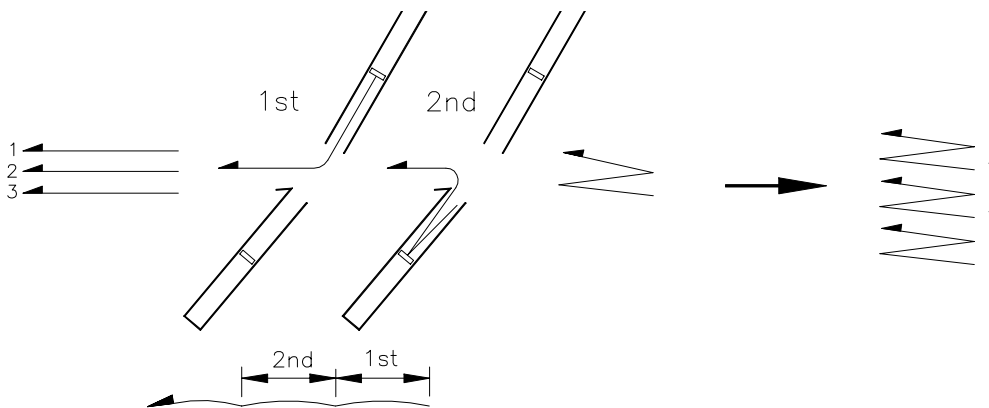

Single (or Half/'V') Fold

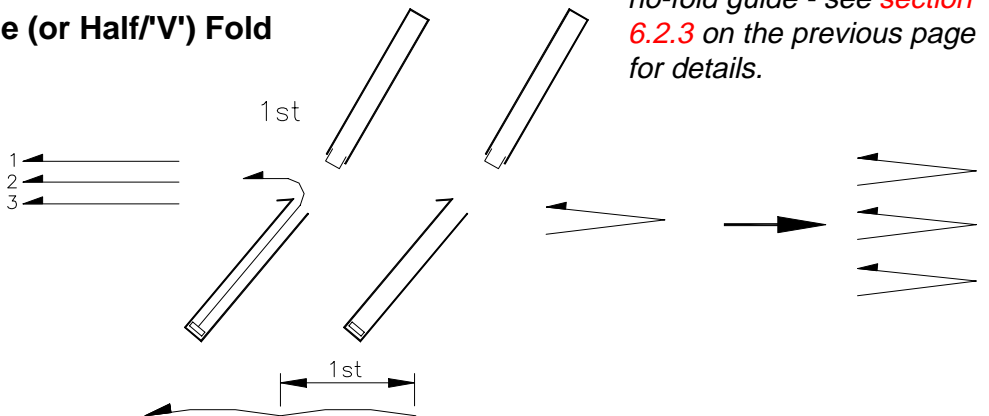

This requires the use of the no-fold guide - see [section 6.2.3](#) on the previous page for details.

Also see the following page for a list of frequently used form sizes.

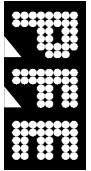

World Leaders
IN MAILROOM TECHNOLOGY

AS300/500 PRESSURE SEALER

Operating Instructions

Frequently used Form Sizes

The list shown below indicates the Fold Plate settings for some typical folded forms.

COMMONLY USED FOLD STYLE	FORM DEPTH	TOP PANEL	MID. PANEL	BOT. PANEL	FORMS LOADED INTO HOPPER	FOLD PLATE 1	FOLD PLATE 2	FINAL ADDRESS
V	11"	5 1/2"	N/A	5 1/2"	Address Panel Up & Trailing	Blocked	5 1/2"	Up
V	11"	5 1/2"	N/A	5 1/2"	Address Panel Up & Leading	Blocked	5 1/2"	Down
Z	11"	3 11/16"	3 11/16"	3 11/16"	Address Panel Up & Trailing	3 11/16"	3 11/16"	Up
Z	11"	3 11/16"	3 11/16"	3 11/16"	Address Panel Down & Leading	3 11/16"	3 11/16"	Down
C	11"	3 11/16"	3 11/16"	3 5/8"	Address Panel Down - Internal Panel Trailing	7 3/8"	3 11/16"	Down
Eccentric C	11"	3 3/4"	3 3/4"	3 7/16"	Address Panel Down - Internal Panel Trailing	7 9/16"	3 13/16"	Up
Eccentric Z	11"	4 1/4"	4 1/4"	2 1/2"	Address Panel Down & Leading	4 1/4"	4 1/4"	Down
Eccentric Z	11"	2 1/2"	4 1/4"	4 1/4"	Address Panel Up & Trailing	2 1/2"	4 1/4"	Up
Z	14"	4 11/16"	4 11/16"	4 11/16"	Address Panel Up & Trailing	4 11/16"	4 11/16"	Up
Z	14"	4 11/16"	4 11/16"	4 11/16"	Address Panel Down & Leading	4 11/16"	4 11/16"	Down
Eccentric Z	14"	3 1/2"	5 1/4"	5 1/4"	Address Panel Up & Trailing	3 1/2"	5 1/4"	Up
Eccentric Z	14"	5 1/4"	5 1/4"	3 1/2"	Address Panel Down & Leading	5 1/4"	5 1/4"	Down
Eccentric Z	14"	3"	5 1/2"	5 1/2"	Address Panel Up & Trailing	3"	5 1/2"	Up
Eccentric Z	14"	5 1/2"	5 1/2"	3"	Address Panel Down & Leading	5 1/2"	5 1/2"	Down
C	14"	4 11/16"	4 11/16"	4 5/8"	Address Panel Down - Internal Panel Trailing	9 3/8"	4 11/16"	Down
Z - Return Envelope	14"	4 11/16"	4 11/16"	4 11/16"	Address Panel Down & Leading	4 11/16"	4 11/16"	Down
Z - Return Envelope	14"	4 11/16"	4 11/16"	4 11/16"	Address Panel Up & Trailing	4 11/16"	4 11/16"	Up
C - Ret. Env. (Xplo-97)	14"	3 1/4"	5 3/8"	5 3/8"	Address Panel Down & Leading	10 3/4" *	5 3/8" *	Up
Double V - Ret. Env.	14"	6 3/4"	N/A	7 1/4"	Address Panel Up & Leading	7 1/4"	3 5/8"	Down

Notes:

1. Forms feed from **Top** of stack by Friction. First fold is **Up** the top vertical plate. Second fold is **Down** the bottom vertical plate. There is **No** nesting feature.
2. The preset marks on the scale for C-Ret. Env. may not accord with the settings shown in the table marked thus * - these settings must be used instead of the preset marks.



6.3 DOUBLE DOCUMENT CALIBRATION

The first time the machine is run (or if the paper type changes), the form must be calibrated to measure its size and thickness. Thereafter, if two forms are fed at the same time, they will be ejected into the top tray before reaching the sealing rollers.

1. Ensure that the hopper tray is loaded (see section 6.1).

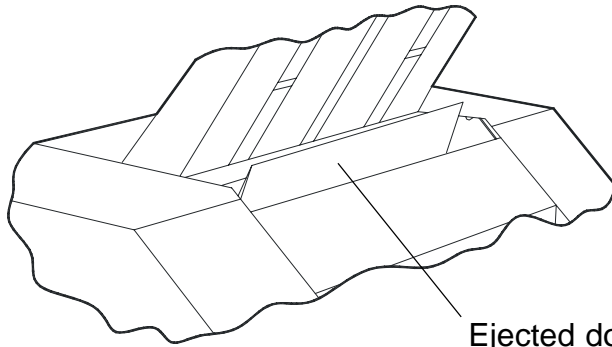

2. Press the calibration button  on the control panel. A single folded document will be ejected in front of fold plate 1. Remove it and check that it consists of only one sheet. If OK, replace it in the slot for sealing.

3. The machine is now ready for use and need not be calibrated again unless the size or thickness of the form used is changed. If a double document subsequently occurs, it will be ejected in the same manner, folded but unsealed. **Note:** if the document does not feed, and the fault 'FLt14' appears, the doubles sensor is dirty or defective. Until this is remedied, only Handfeed mode can be used (see below).

SECTION 7 HANDFEED OPTION

If required the machine can operate in manual mode, allowing, for example a single or small number of documents to be processed without setting up the rest of the machine. This function may also be used for sealing diverted forms.

1. Pre-fold the document by hand to the required fold lengths (see section 6.2.4 for fold options), or remove the diverted form from the slot in front of fold plate 1.

2. Insert the folded document, with crease downwards into the slot in front of fold plate 1. Ensure it is **fully** inserted. The message 'hFEEd' will appear on the display. Press the Run button to feed the document

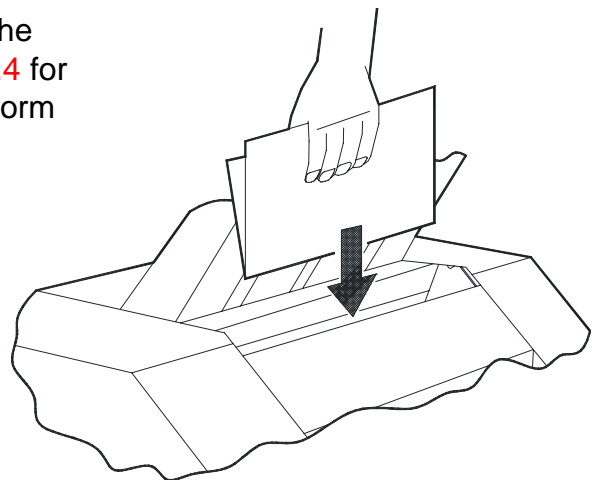

3. Repeat as often as required.

Note: if the motor can be heard running, wait until it stops before inserting the form.



AS300/500 PRESSURE SEALER

SECTION 8 OPERATOR MAINTENANCE

After a long period of use, dirt and toner can build up on the fold and seal rollers, and dust can cause the sensors to become obscured. This will need to be cleaned off to ensure reliable operation.

8.1 Cleaning the Fold and Seal Rollers

Fold Rollers

The rubber fold rollers should be cleaned using a lint-free cloth and an approved, non-spirit based roller cleaning fluid. **Be sure the machine is disconnected from the power source first.** To gain access, hinge fold plate 1 backwards and clean the full width of the three rollers.

Front Seal Roller

There are three seal rollers, one at the front of the machine, and two at the rear. The front roller is accessed by raising the cover in front of fold plate 1 while the fold plate is open - it will click-stop in the open position. Clean the full width of the roller. Now replace the covers, reconnect the machine and use the jog function (see section 8.3) to increment the rollers. Disconnect, and raise the covers to clean the rollers again. Repeat this until the rollers are fully cleaned.

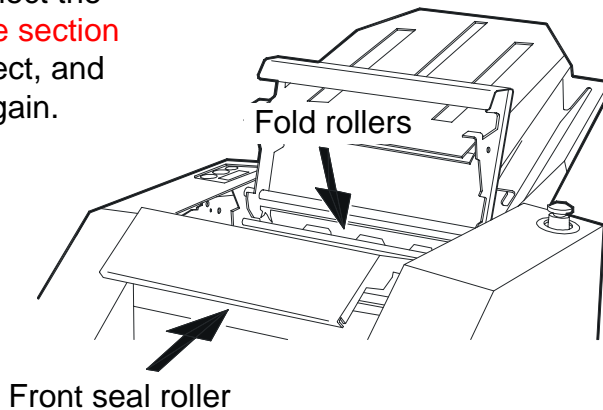

Rear Seal Rollers

The two rear rollers are accessed by raising fold plate 2 - pull the spring plunger back and lift the upper plate, then turn the lock key to release the lower plate. The click-stop will hold the plates in the open position. Clean the full width of the two rollers. Now lower the fold plates, reconnect the machine and use the jog function (see section 8.3) to increment the rollers. Disconnect, and raise the plates to clean the rollers again. Repeat this until the rollers are fully cleaned.

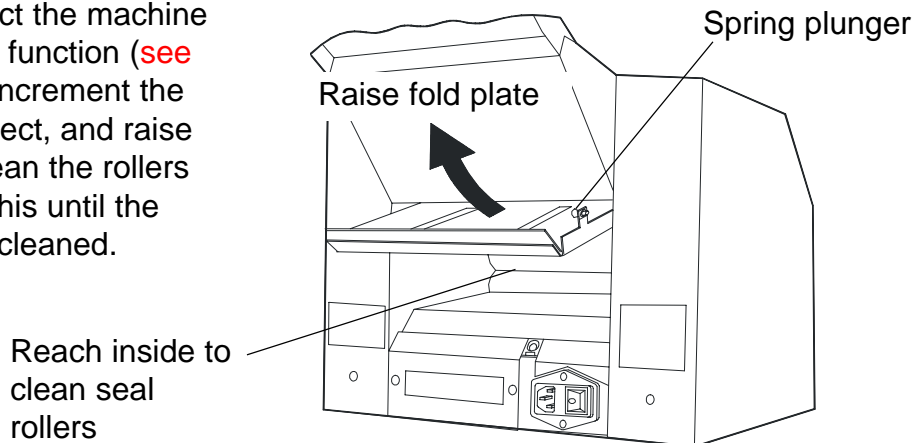



8.2 Cleaning the Sensors

The optical sensors on the machine consists of two halves, spaced slightly apart. They should be cleaned at regular intervals using **only a non-flammable airduster**, ensuring that both halves are cleaned. **Do not use a liquid solvent on the sensors.**

Hold Point & Double Document Sensors

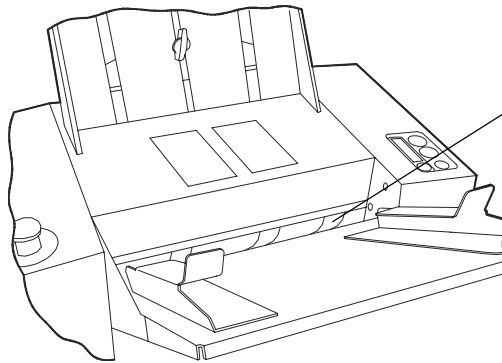

Depress the hopper tray and direct the air jet either side of the right-most feed roller. Spray liberally.

Divert Sensor

Direct the air jet into the gap shown and spray liberally to ensure both halves are cleaned.

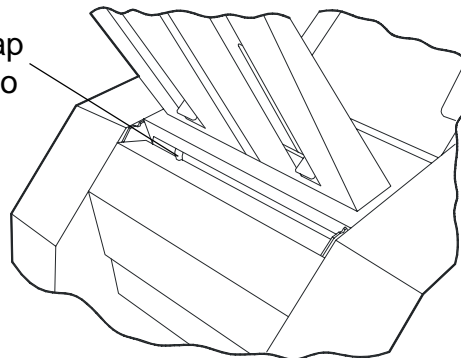

Eject Sensor

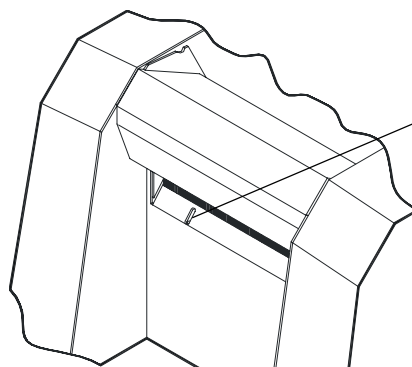

Direct the air jet onto the sensor shown, and also into the eject slot just above it. Spray liberally.



IMPORTANT! IF OPERATING PROBLEMS OCCUR, CLEAN THE SENSORS FIRST BEFORE INVESTIGATING FURTHER CAUSES.



AS300/500 PRESSURE SEALER

8.3 Clearing Paper Jams

If paper jams occur, they can usually be cleared by using the jog function, which operates the machine in short spurts to drive out the jammed document in a controlled manner. If the jam cannot be driven out by using the function on its own, try alternating jogs with re-opening the covers and attempting to pull out partially cleared paper. **The jog function will only operate if all covers are closed.**

The function will only be available if the machine has stopped with a fault showing on the display panel - a fault number will alternate with a scrolling message describing the error. Now press the Run button  and you will be asked if you wish to use the jog function. To jog forward, press the Run button again, and the machine will jog. To jog backwards press the Calibration button . This can be repeated as required until the Stop button  is pressed, which will clear the jog function, and also the fault message. Assuming the cause of the fault has now been removed, operation can continue by pressing the Run button.

Jams are most likely to take place in the infeed or fold roller areas, or in the fold plates. Raise fold plate 1, and if the paper is visible and the jam is obvious, remove the paper if possible. If it cannot be dislodged from the rollers, close the fold plate and operate the jog function as above. Jams occurring in fold plate 2 can be cleared by lifting the upper or both parts of the plate to gain access.

If the jam is internal (ie. in the sealer rollers), the jog function may have to be operated quite a few times to clear the paper. If all attempts to remove the paper fail, contact the Service Department.

Cleaning Rollers

If you are using the jog function to clean rollers, it will be necessary to force a fault before the function will operate. To do this, simply remove all paper from the machine and press the Run button - after a few seconds, an out of paper fault will be flagged and the jog function can be used.

Other Operating Problems

Other problems may occasionally occur, caused by situations other than paper jams. A Troubleshooting Guide to assist with rectifying such problems is shown in section 10 on page 18. Additionally, any fault that occurs will display a fault message on the control panel. An explanation of the fault messages, and the action to take is shown in section 11 on page 19.

If operating problems occur, first ensure that the paper is within specification, and that the orientation is correct. Also check that the fold plates are correctly set (see section 6.2)



SECTION 9 SUPERVISOR MODE

Supervisor Mode reveals various statistics about the machine, namely Eprom version number, total running hours and overall forms count. To enter the mode, press the Stop button **while** the machine is displaying the 'HELLO' message after switching on. The message 'SUPeRvISOr' on the display indicates that the mode has been entered.

To step down through the various functions, press the Reset button on the control panel. The functions are described below:

Eprom: Displays the Eprom version number in the format 'Vn-nn' where n-nn is the version of the Eprom fitted to the CPU board.

Hours Count: Displays the total number of hours to date that the machine has run. The format is 'nnn_n' which equates to the number of hours (eg 082_7 means 82.7 total running hours to date).

Overall Count: Displays the total number of forms to date that the machine has processed. The format is 'nnnnnnn' where nnnnnnn is the forms count in units of 100. As the count is up to 7 digits and only 5 can be displayed, pressing the Run button whilst in Overall Count will display the 2 lowest (rightmost) digits. Note that this Overall Count is **not** reset by pressing the Zero Reset button.

Pressing the Reset button again displays the message 'End' to indicate that the end of Supervisor mode is reached. Pressing the button again loops back to the start of Supervisor Mode. Press the Stop button or switch off the machine to exit the mode.



SECTION 10 OPERATOR'S TROUBLESHOOTING GUIDE

If problems occur, refer to the guide shown below before contacting the Service Department.

<u>PROBLEM</u>	<u>SUGGESTED CAUSE AND REMEDY</u>
1. Machine will not run.	1. Ensure emergency stop button is not depressed and that power cord is plugged into power outlet.
2. Forms not feeding, although machine is running.	2. Forms improperly loaded - ensure leading edges are firmly against chassis bridge and that the tray is depressed (see section 6.1).
3. Forms feeding skewed.	3. Ensure side guides are properly adjusted (see section 6.1).
4. Double documents occurring frequently.	4. Paper type has been changed - recalibrate machine (see section 6.3).
5. Jam occurring in folder when machine is first run.	5. Fold plates not set - see section 6.2 .
6. Forms keep stopping in folder area.	6. Dirty fold rollers - clean (see section 8)
7. Form doesn't exit first fold plate.	7. Plate is set too deep for form length - reset the plate (see section 6.2).
8. Form exits through slot in front of fold plate 1 but is not a double document.	8. Calibration or diverter fault - recalibrate first (see section 6.3) and if this fails, contact the Service Department.
9. Forms not sealing, or failing to seal completely.	9. i) Forms loaded wrong way up - turn over. ii) Defective cohesive - check paper is within date and test a sample using handfeed (see section 7). iii) Defective seal rollers - contact the Service Department.
10. 'Flt6' error message occurring.	10. Remove diverted form from in front of fold plate 1.
11. 'Flt8' error message occurring.	11. Receiving tray full or not sufficiently extended.



AS300/500 PRESSURE SEALER

Operating Instructions

SECTION 11 ERROR/STATUS MESSAGES

If operating faults occur, a code will appear on the control panel display, for example:



where 'nn' = one of the numbers indicated below.

The fault code will alternate with a scrolling description of the problem. If more than one fault has caused the machine to stop, each code and description will cycle through before repeating. If you press the 'Run' button while any error is displayed, you will be asked if you wish to operate the Jog function (see Operating Instructions section 8.3)

<u>FAULT CODE</u>	<u>DISPLAYED DESCRIPTION</u>	<u>ACTION TO TAKE</u>
FLt1	Load hopper	Hopper is empty, or form not fed to hold point. Reload, or check paper is correctly loaded (sect. 6.1).
FLt2	Feed fault	Paper jammed at infeed - clear jam (sect. 8.3).
FLt3	Hand feed fault	Form not fully inserted when hand-feeding. Ensure it is pushed fully down (sect. 7)
FLt4	Doc did not arrive at divert	Form, (possibly a double or calibration document) is jammed in fold rollers or infeed - clear jam (sect. 8.3).
FLt5	Doc should not be at divert	Diverter solenoid may be stuck - contact Service Department.
FLt6	Divert full	Unretrieved form is in divert/hand feed slot - remove it.
FLt7	Doc did not arrive at eject	Form jammed on route to output - clear jam (sect. 8.3).
FLt8	Doc failed to clear eject	Form cannot eject properly - check output tray is correctly adjusted.
FLt9	Doc should not be at eject	Diverter solenoid may not be operating - contact Service Dept.
FLt10	Eject sensor obscured	Check that a form is not blocking the sensor. Clean all sensors (sect. 8.2).



AS300/500 PRESSURE SEALER

FLt11	Chip error	Fault with EPROM chip - contact Service Department.
FLt12	Diverted double doc	Double document correctly diverted. Remove, and check paper in hopper is not stuck together.
FLt13	Undivertable double doc	Double document could not be diverted - check for jam in fold rollers (sect. 8.3).
FLt14	Ddcal fault.	Clean double document sensor, or call Service Dept. to replace. Machine can only be used for handfeed until fault is fixed.
FLt15	Drive stall	Motor has stalled - ensure forms do not exceed maximum weight (sect. 1).